

TAP OLÉ

RESPONSABLE TÉCNICA: Ganecha Gil Gracia

Tlf :+34. 649. 680. 867 neganesh@hotmail.com

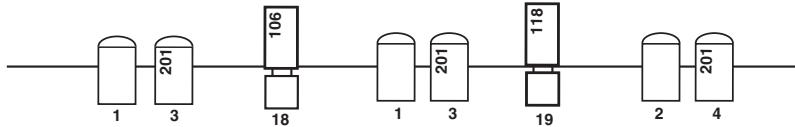
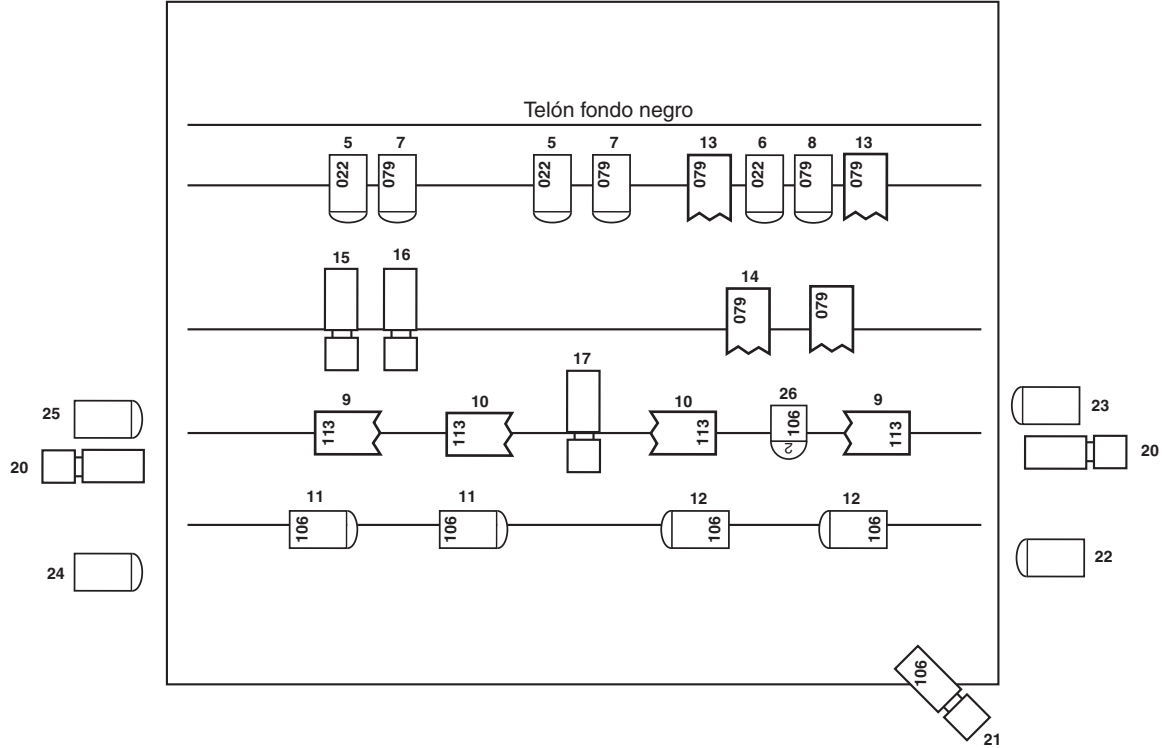

	RECORTE 750 Kw 25/50
	PC 1Kw
	FRESNEL 1Kw
	PAR 64 CP61

Nº		CH DIMMER
Nº		COLOR